

Although initially developed for NASA, the features of iQRAS allow it to be applied to a wide range of applications, including aerospace, military, transportation, as well as medical procedures. iQRAS was designed to be used by a wide range of engineers and analysts. It is suitable for use by safety engineers who are seeking to enhance their safety analyses.

iQRAS is the latest addition to Item Software's suite of risk and reliability-software tools. The latest version of the software completes the transformation from the original software as developed by the University of Maryland and NASA. The new environment provides an extensive set of editing and reporting capabilities, in line with those found in ITEM ToolKit, our flagship suite of tools for reliability, availability, maintainability and safety analysis.

On the computational side, iQRAS offers state-of-the-art algorithms that are both highly efficient and, unlike conventional solution methods used in most other tools, are not subject to often significant approximation errors.

Modeling and Analysis Capabilities

With iQRAS you can develop risk models in the form of event sequence diagrams and fault tree models. Event Sequence Diagrams (ESD) describe the possible risk scenarios following potential perturbations of normal system operations. Pivotal events in the risk scenarios are further detailed using fault tree models or other distributions. This defines the occurrence of those pivotal events as logical combinations of one or more basic events. Each scenario eventually leads to an end-state and consequence that designates the severity of the outcome of the particular scenario.

The Event Sequence Diagrams are organized using a system hierarchy, consisting of structural or functional decomposition. A mission timeline allows the break down of the overall mission into multiple mission phases. This organizing capability makes for easy navigation between the potentially large numbers of event sequence diagram models, and tailors the risk scenarios to the particular conditions of a mission phase.

A wide variety of quantification models are available to specify the likelihood of occurrence of basic events. These include standard demand-based and time-based reliability models, as well as highly customizable models that take advantage of the optional link with Mathematica®.

Additionally, iQRAS contains a centralized common cause failure-modeling feature. This enables common cause failure effects to be introduced

across multiple fault trees. This feature significantly reduces the burden of introducing and maintaining common cause failure events in a model.

Parameters in all models are specified by means of uncertainty distributions, which can be formed by common parametric models such as the lognormal, uniform, gamma, beta distributions, and probability histograms. For each distribution iQRAS contains flexible input modes that allow the parameters of the distribution to suit the needs of the analysis.

Risk results can be obtained at the fault tree, risk scenario, or end state level. They can also be aggregated over multiple event sequence diagrams associated with a specific portion of the system hierarchy and/or a portion of the mission timeline. Analysis features include the estimation of total probability of reaching specific (undesirable) end states; the ranking of risk scenarios or risk scenario initiators by total risk contribution; cut-set analysis for the identification and ranking of critical combinations of events leading to a particular end state or consequence; and the computation of importance measures indicating the impact of individual basic events on the overall risk.

iQRAS employs state-of-the-art Binary Decision Diagram-based analysis techniques, which are not subject to approximation errors found in traditional analysis techniques. Studies have shown these errors may span orders of magnitude. Monte Carlo (Latin Hypercube) Sampling including based uncertainty propagation techniques are used to determine the uncertainty surrounding numerical results. Separate importance measures are provided to identify the events contributing the most to overall uncertainty.

iQRAS Major Features

Risk Model Analysis

- Exact results generated by Binary Decision Diagram (BDD) based solution methods
- Computation of cut-sets, risk importance measures, probabilities for fault trees and ESDs
- Uncertainty propagation and uncertainty importance measures
- Risk aggregation over event sequence diagrams, end state types, and system or functional hierarchy

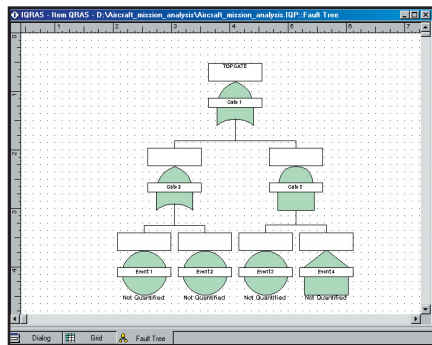

Quantification Models

- Extensive set of time-dependent and demand based component reliability models
- Easy-to-use specification of uncertainty distributions for model parameters
- Mathematica® (not included)

Incorporation of Other Models

- ITEM ToolKit

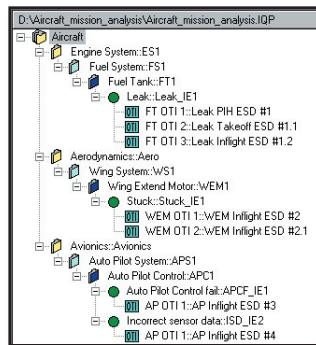

Gate ESD Detail Results

- User defined number of cut sets that iQRAS will calculate based on probability. iQRAS can also display the actual number of cut sets for the analyzed system. For example; the advanced BDD algorithm could calculate the top 500 cut sets, even if the actual cuts were more than a billion, within seconds
- Users can get detailed uncertainty results for any gate

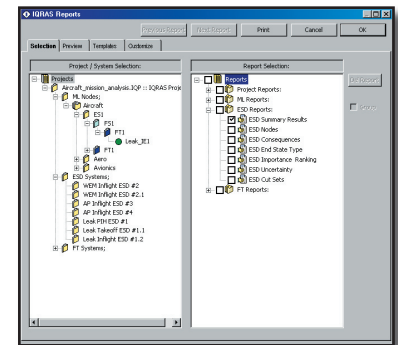

Organization of Risk Models

- Organization of ESD models by user-defined system or function hierarchy
- Organization of ESD models by mission phases and operational time intervals
- Easy navigation between the ESDs and fault trees

Common Cause Failure Modeling

- Centralized definition of common cause failure event groups
- Automated application of common cause failure expansions to selected fault tree models
- Support for Alpha and Beta Factor models
- Common cause failure expansions within and across fault trees

Event Sequence Diagram

Quantification

- Quantification of ESDs using the fault tree list created in the fault tree editor
- View and attach fault trees from the pivotal/initiating event quantification dialogs
- The fault tree editor can be opened and used independently to create and quantify the fault trees
- User can change ESD events designators

Reporting, Export of Risk Models and Results

- Export of models and results to Microsoft Word, Excel and Access
- Extensive reporting capabilities using Crystal Reports™

iQRAS Feature Highlights

Event Sequence Diagram Editing

- User-defined end state types and consequences
- Support for scenario transfer points
- Maximum flexibility to modify visual appearance of diagrams
- Auto pagination, auto arranging
- Copy/paste entire, or only segments of, the ESD

Versatile Fault Tree Construction

The foundation for building a fault tree is the versatile user interface within iQRAS. It is capable of creating fault trees via a hierarchy mechanism, or a traditional fault tree diagram. The fault tree diagramming mechanism is a feature rich, fully customizable, diagramming tool.

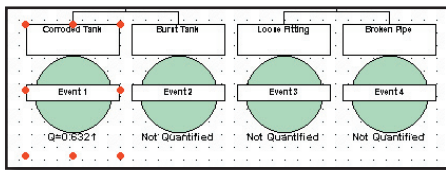

- Build fault trees in the traditional way by adding gates and events in the diagram
- Build fault trees using a hierarchical view, by adding gates and events to hierarchy nodes
- Fault tree diagram and hierarchy are automatically kept synchronized
- Change sizes and colors of gates and events, fonts, labels and text boxes
- Add text, header and footer information directly to diagrams

Fault Tree Editing

- Unavailability and uncertainty calculations
- Full set of logic gates and event types
- Reuse of fault tree models across multiple event sequence diagrams
- Standard visualization as well as condensed tree-views
- Maximum flexibility to modify visual appearance of diagrams
- Hierarchical and tree views of fault tree
- Auto pagination, auto arranging

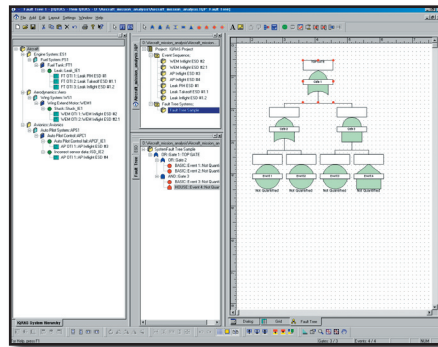

Fault Tree Linking

- Link fault tree logic to other fault trees or gates. Create fault trees in smaller, manageable pieces

Multiple Projects: Fault Trees & Event Sequence Diagram

- Effortlessly creates, reviews and analyzes multiple fault trees and ESDs simultaneously
- Merge all or a portion of a fault tree to create a master fault tree
- Manage fault trees from multiple projects

- Allow creation of a fault tree by reusing all or a portion of an existing project
- Copy/paste gates and events between projects and fault trees

Auto-Arrange and Auto-Paginate

- Automatically arranges all gates and events in the fault tree following user-defined settings
- Automatically paginates fault trees according to user defined page settings. Transfer gates are added at appropriate places, dividing into multiple pages

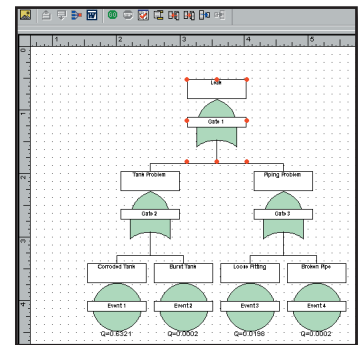

MS Word Transfer

- Automatically transfer fault tree diagrams into MS Word™ documents